

3-D Printed Pencil Topper

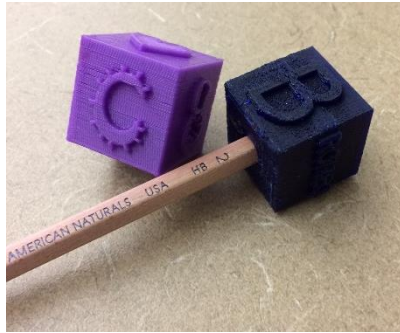

Tutorial Created By: Brennan Ralston
Class of 2015

In this tutorial you will learn how to create a 3D model in Inventor. In this case you will be designing a pencil topper for an elementary student created with their specifications. These pencil toppers will be printed on the 3D printer and given to them. If time allows, create one for yourself!

3-D Printed Pencil Topper

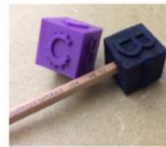

Mrs. Dossin's Drafting class at the RETC will be learning how to design a 3-D object on the computer and then print it on the 3-D printer. Her class would like you to be a part of this project. Please fill out the information below so a high school student can design a pencil topper made especially for you.

1. What is your name? _____
2. What is the first letter of your first name? _____
3. What is the first letter of your last name? _____
4. What is your favorite number? _____
5. What is your favorite shape? _____
6. What is your favorite color? _____
7. What is your teacher's name? _____

Example of the form an elementary student filled out.

Save your file in the G: 00 PENCIL TOPPERS folder. It should be named specifically in the following format so it will help streamline printing, **"HOUR-YOUR FIRST AND LAST NAME-PENCIL TOPPER- COLOR".ipt** so for example, ***3-EVVA DOSSIN-PENCIL TOPPER-GREEN.ipt***

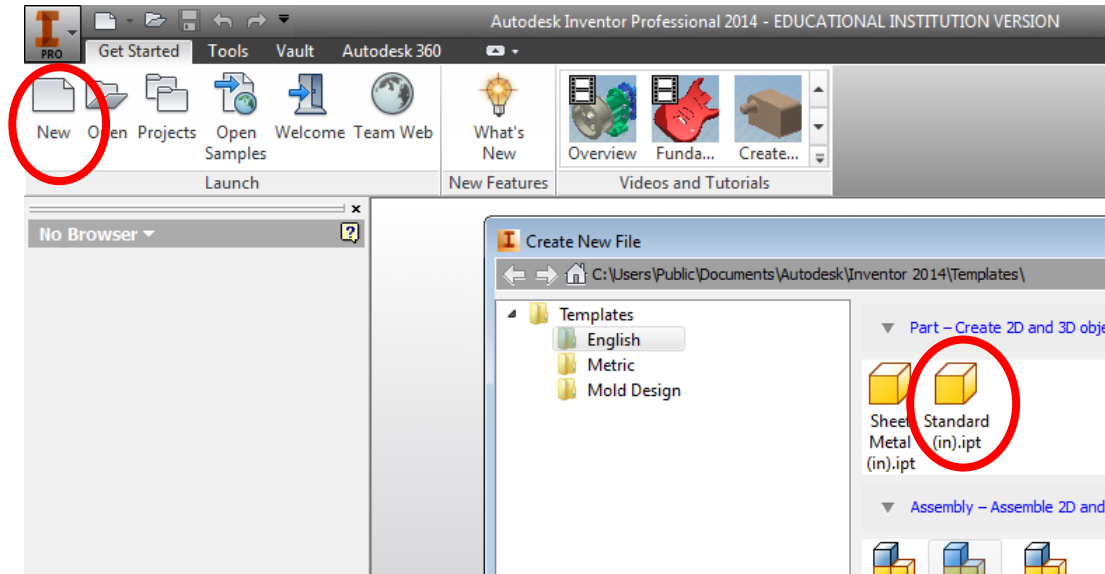

1. First you are going to click on the new button in the top right corner. Then after it opens up that small window you will want to click on the **STANDARD (IN).IPT** file from the English folder.

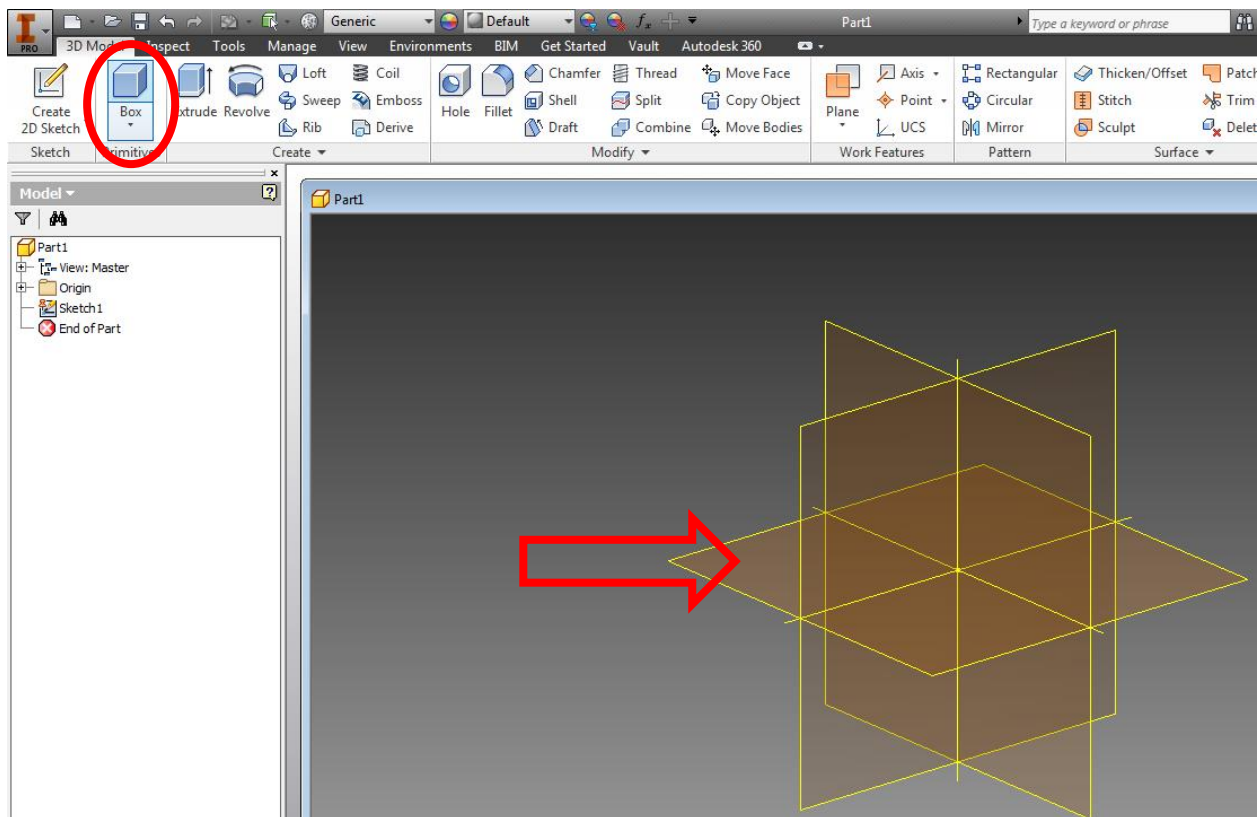

2. Now you are going to click on the **BOX** button then select the horizontal plane that is being pointed to in the picture above. (If the **BOX** option is not showing up for you, right click on the ribbon, select **SHOW PANELS**, click on **PRIMITIVES** and then **BOX** option will show up.)

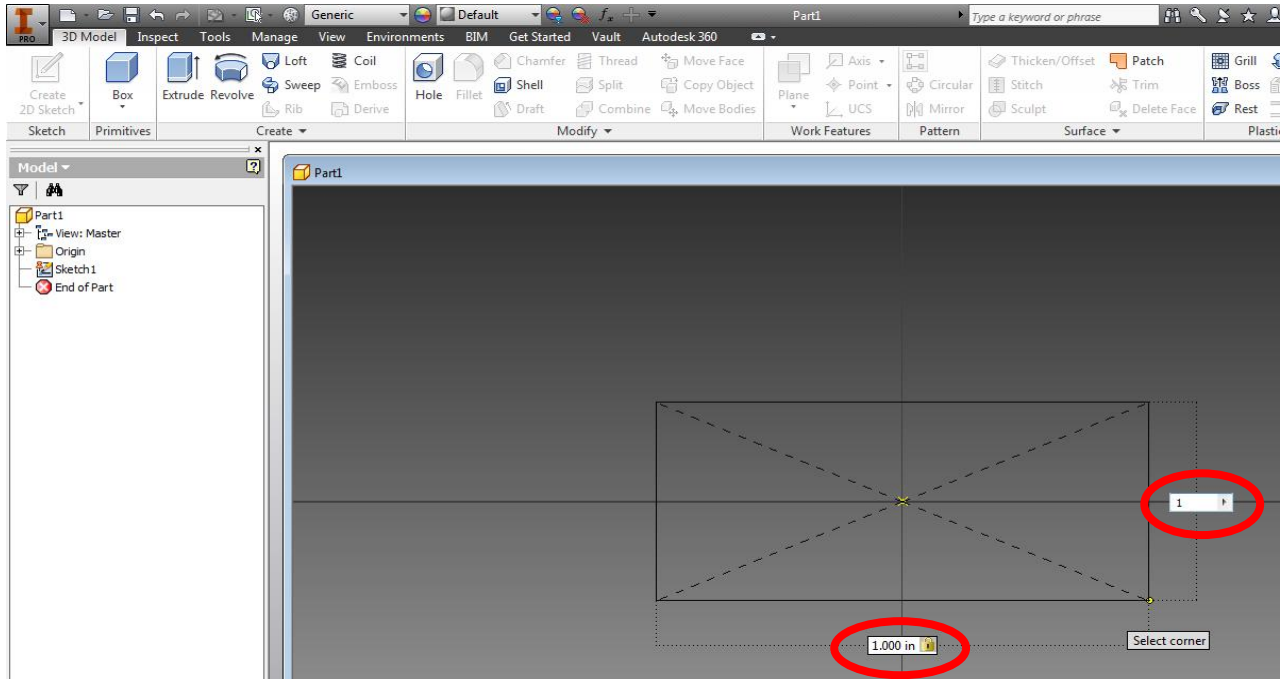

3. Now click on the origin (center) and then you are going to type in **1** for the length then press **TAB** and then you can type in **1** for the width.

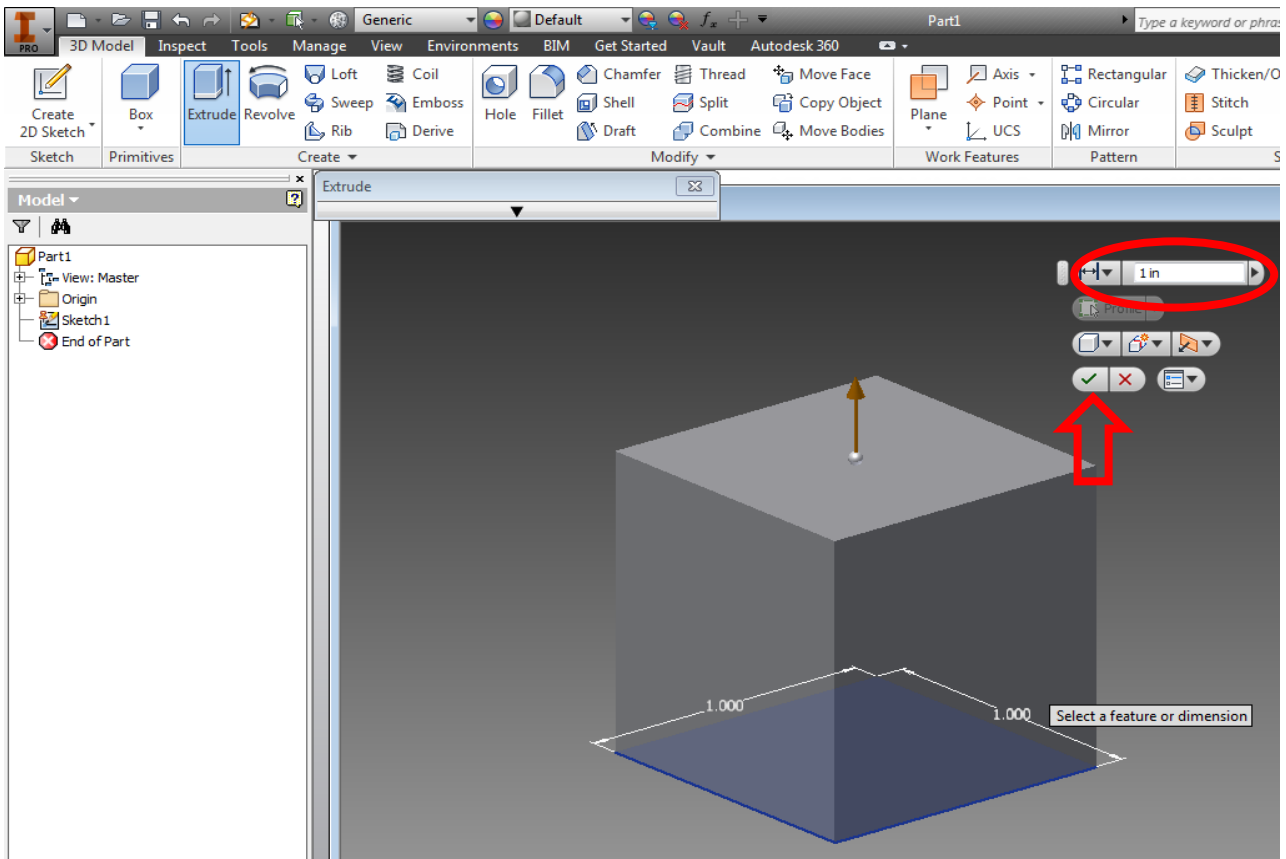

4. Now click on the **EXTRUDE** button right next to the box button. You are going to want to then type in **1**, then click on the green check mark after.

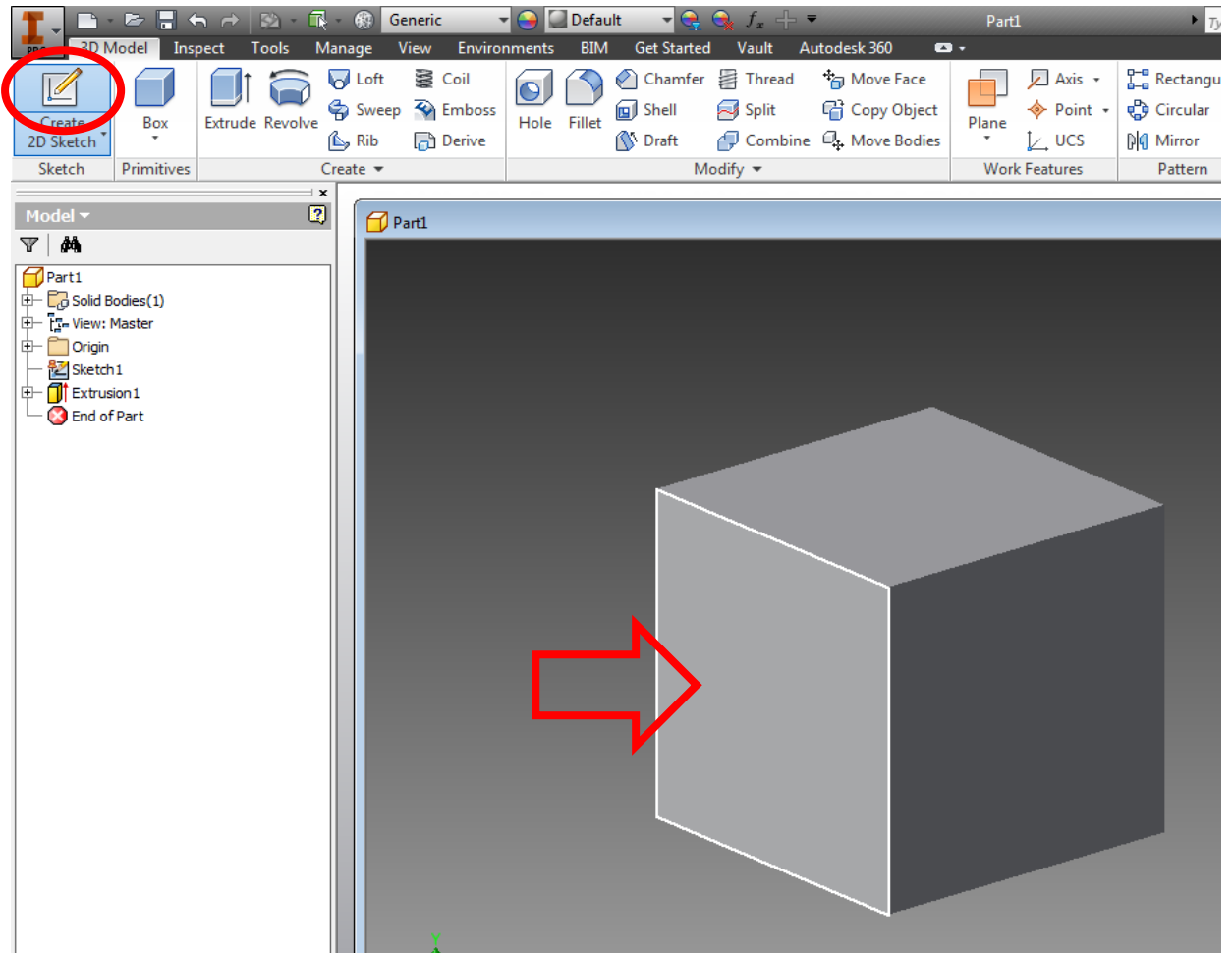

5. Next you are going to click on the **CREATE 2D SKETCH** button in the top left corner and then select the face of the cube that the arrow is pointing to.

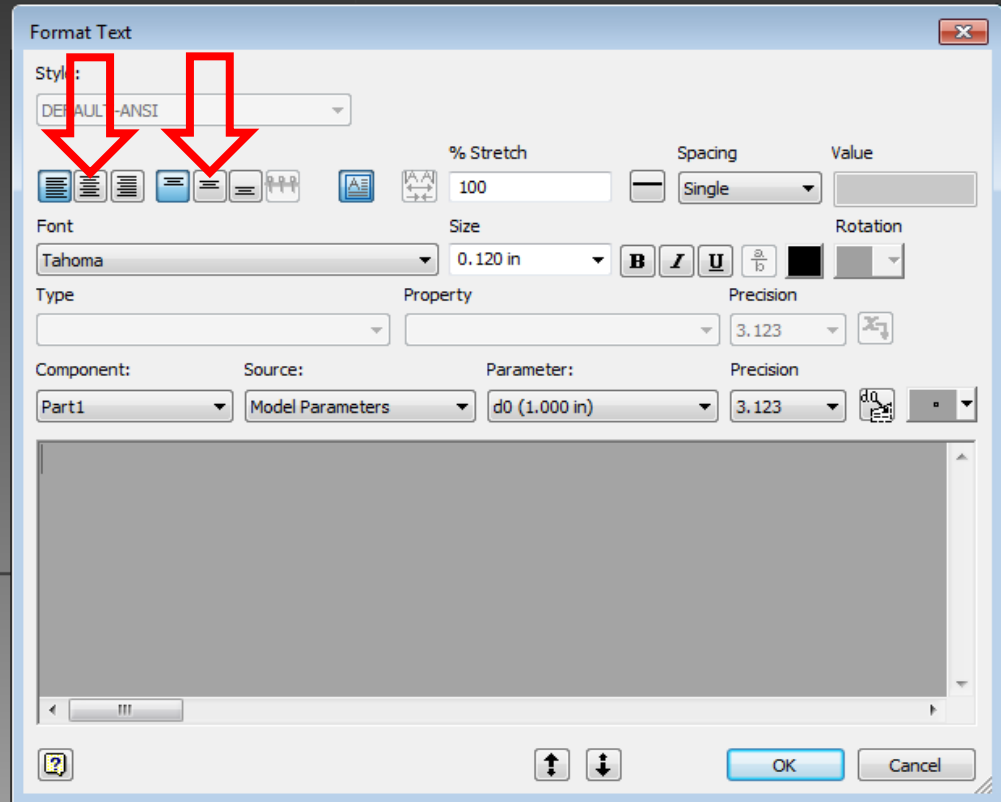
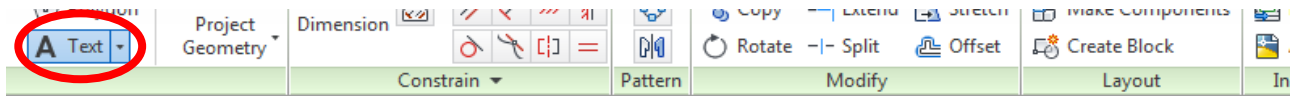

6. After you have done that you are going to want to click on the **TEXT** button then click anywhere on your drawing space but not on the cube itself, Next make sure you click on the two center buttons that the two arrows are pointing to, Then you can select your font and the size will be **.8** and then you are going to want to type in the first letter of the persons name, when you are done click **OK** then click **FINISH SKETCH** in the top right corner of the screen.

**NOTE: When selecting a font, do not pick one that is of a thin style because the 3D printer will not be able to print it clearly.*

**Use a CAPITAL Letter (unlike what images below show) because the letters represent the student's names and because at the kindergarden level they are familiar with this.*

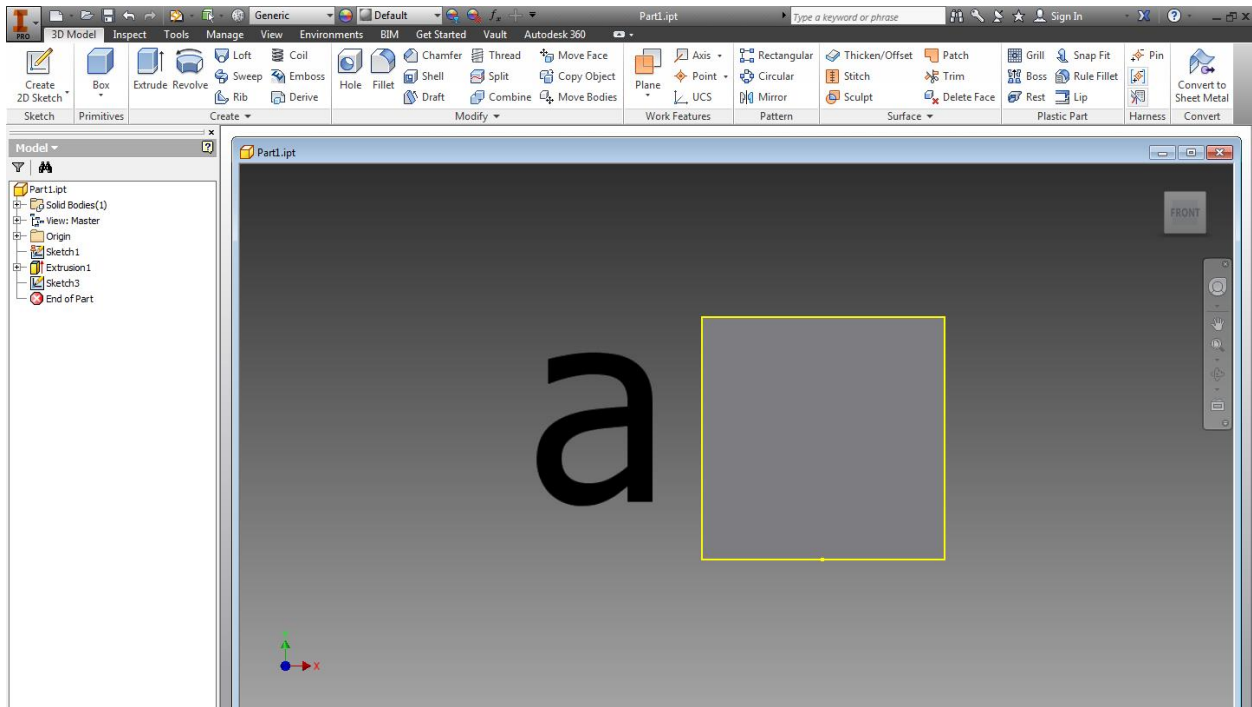

This is what the letter should look after you clicked ok.

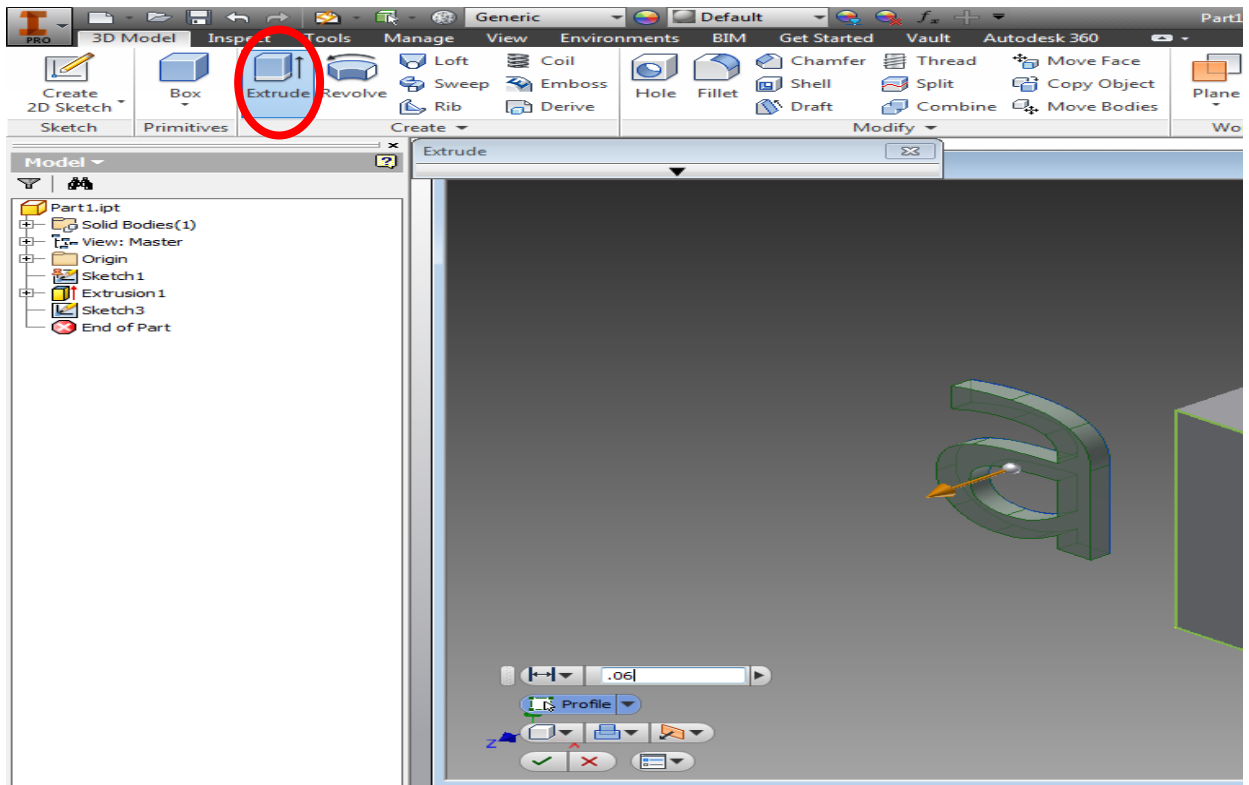

7. Now you are going to want to click the **EXTRUDE** button and click on your letter, then you are going to type in **.06** as you extrude length and the when you are done click the green check mark.

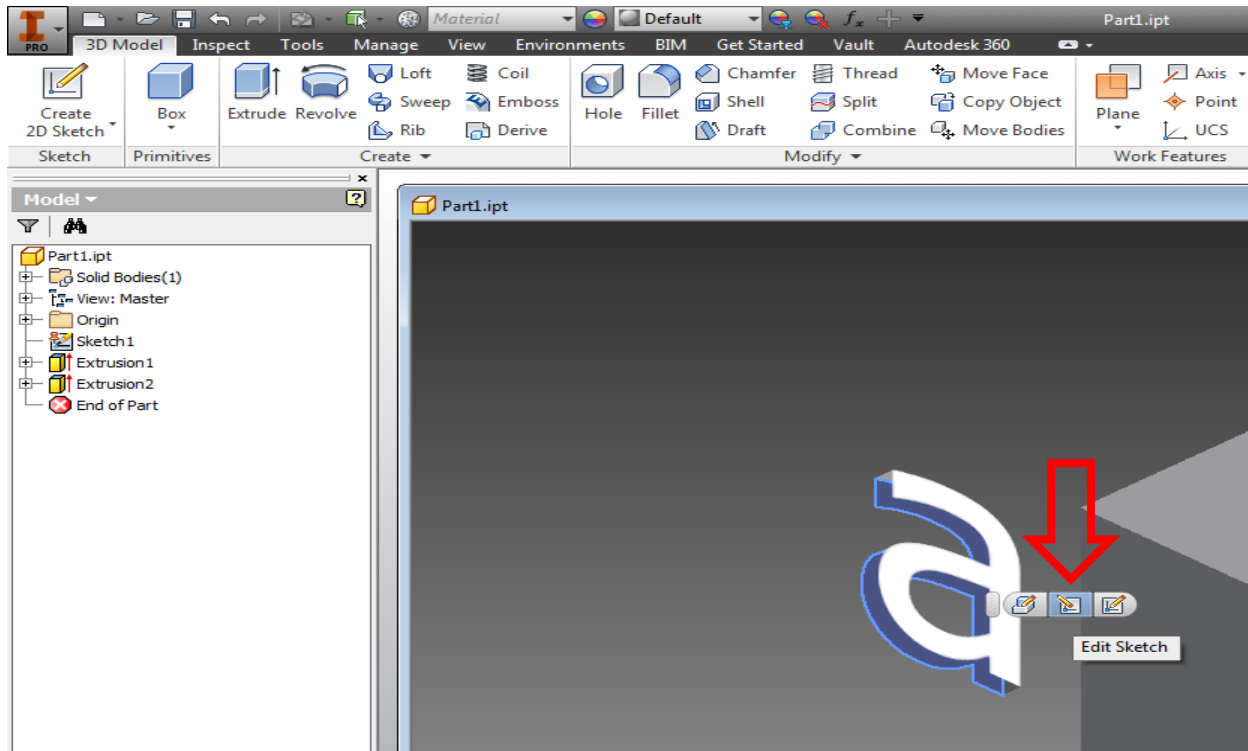

8. Now click on the face of the letter and then select the **EDIT SKETCH** button.

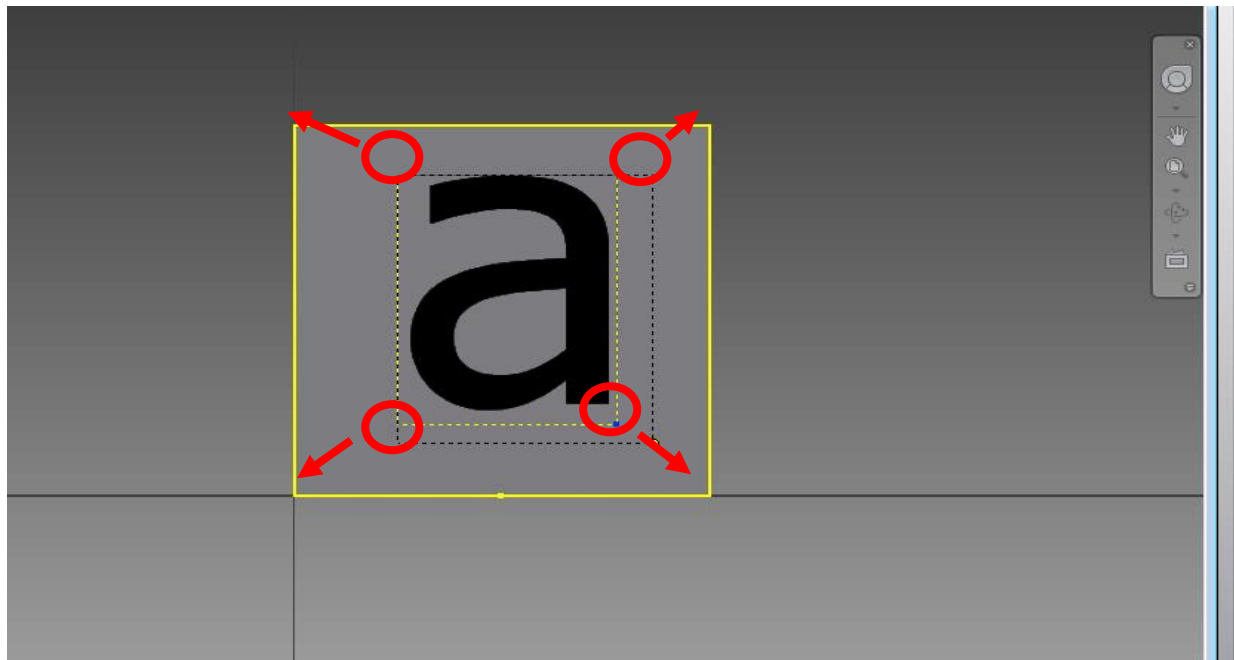

9. After you do this you are going to want to drag your letter on to your cube then click on each corner of the text box and drag them to the corners of the cube.

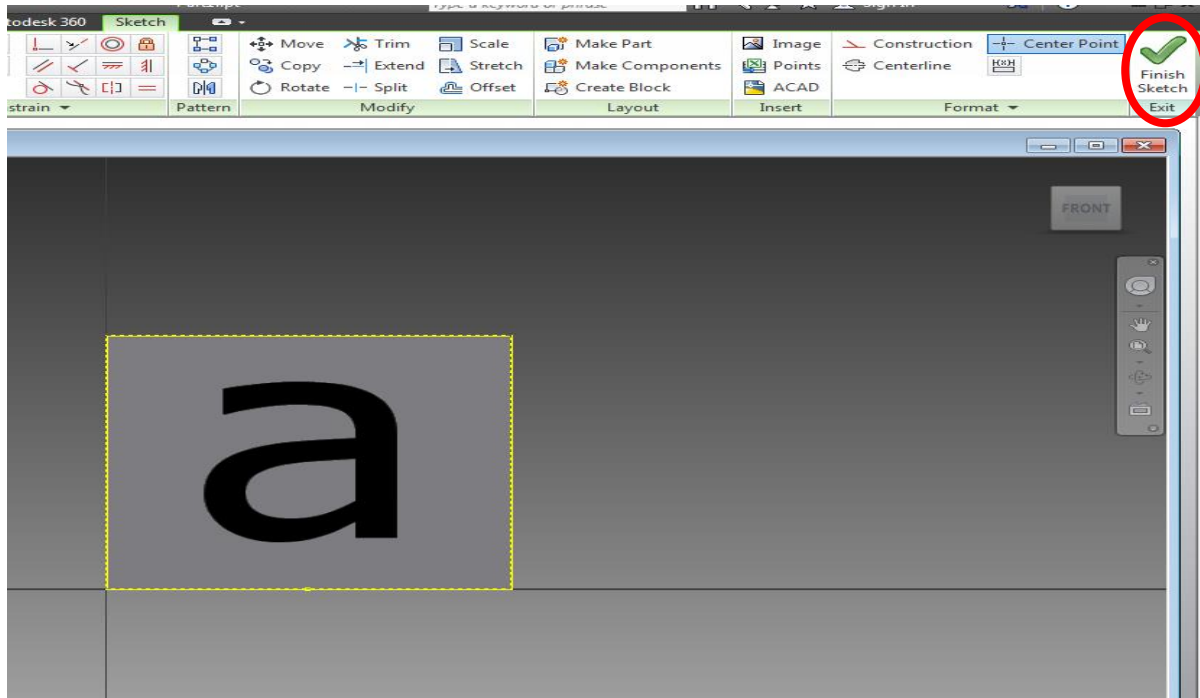

10. This is what it should look like after you drag all of the text box corners to the cube corners, then when it is all set you are going to click on the **FINISH SKETCH** button in the top right corner.

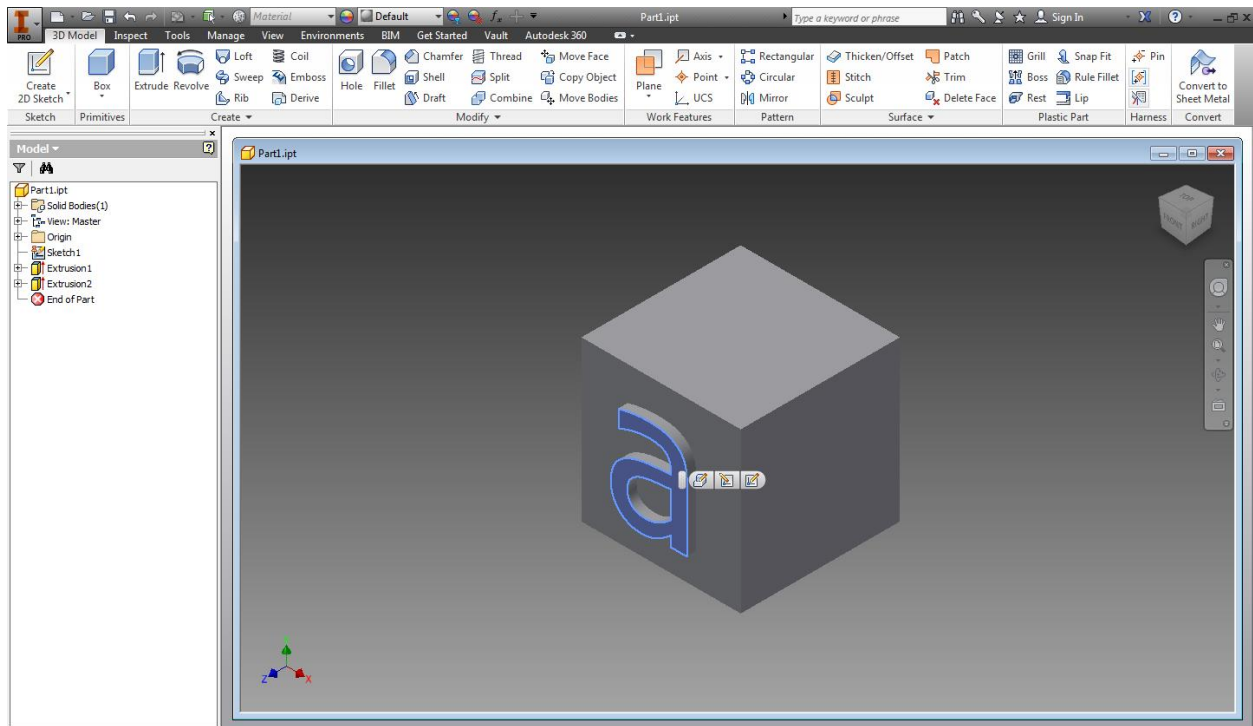

11. Now your letter should be centered on the cube and look like this.

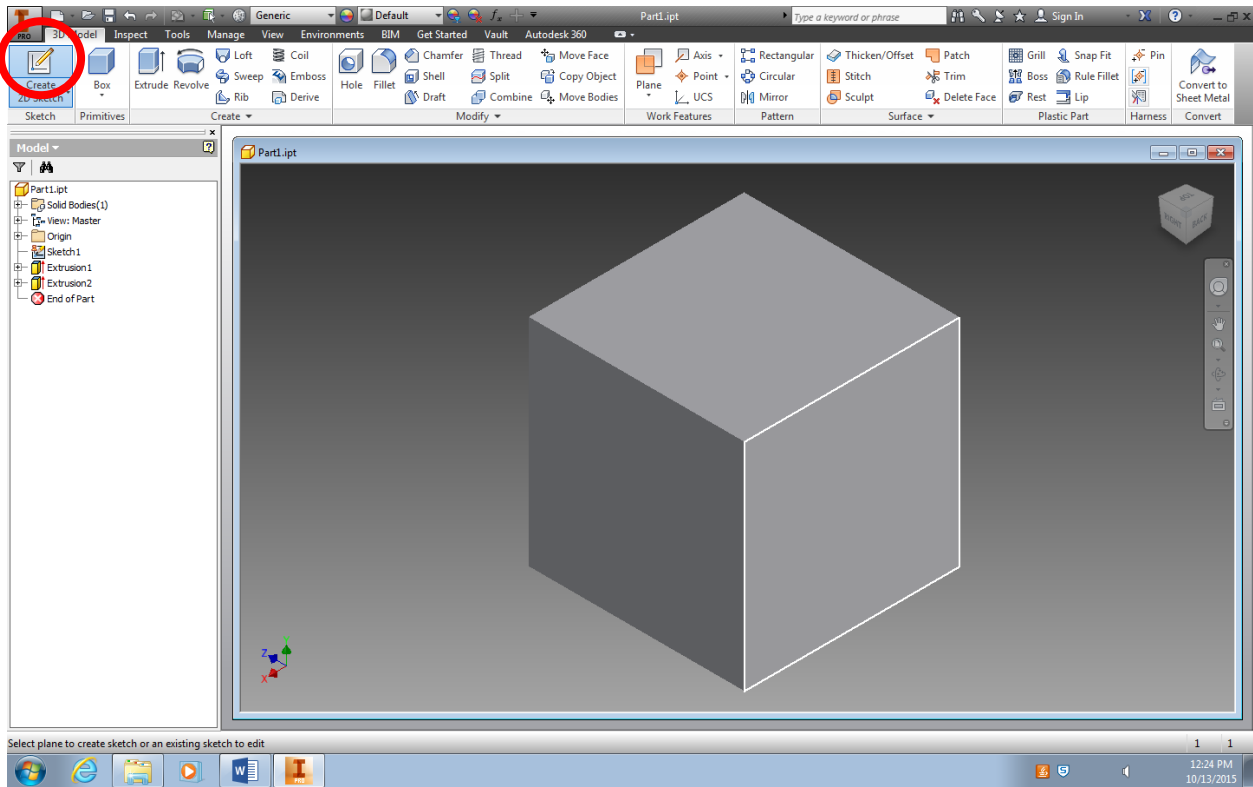

12. Using the View-cube in the upper right corner, rotate your pencil topper so that you can click on the **opposite face** from the one you just drew on and repeat steps 5-11 but the letter on this face will be the First Letter of the Last Name.

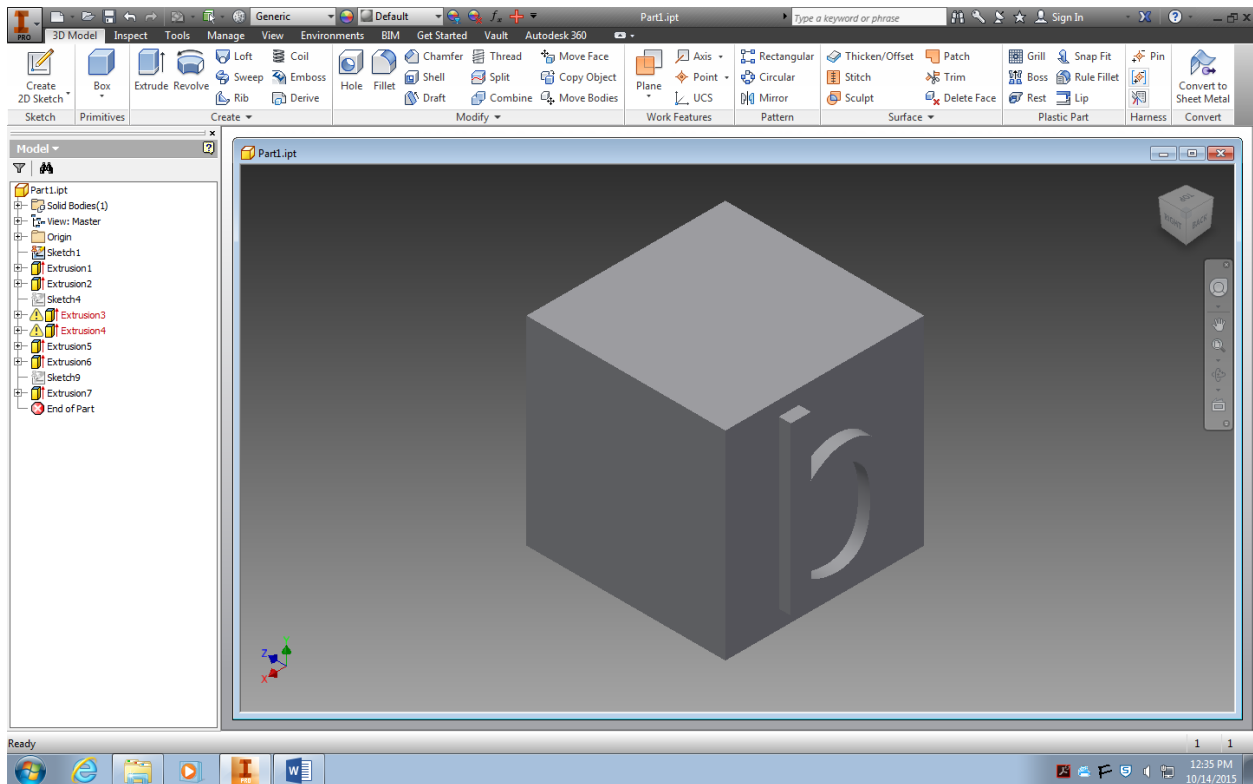

13. This is what it should look like after you repeat those steps.

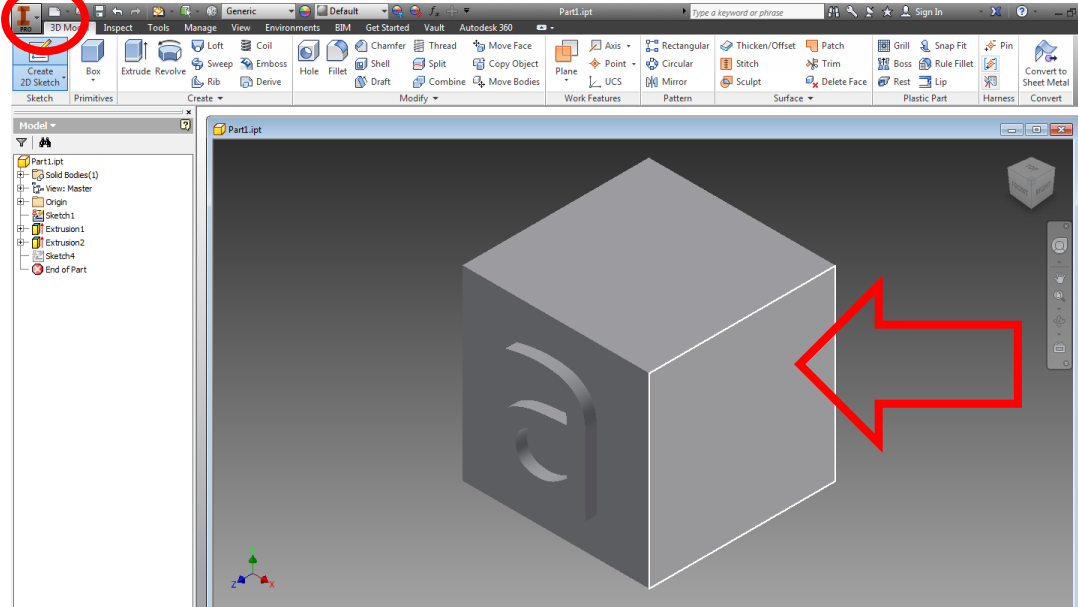

14. Now click on the **CREATE 2D SKETCH** button then select face next that is being pointed to in picture above and then repeat steps 5-11 but now you are going to put their favorite number.

* Depending on the number your elementary student selected you may have to decrease the size of the font in order to have it fit on the face on the cube.

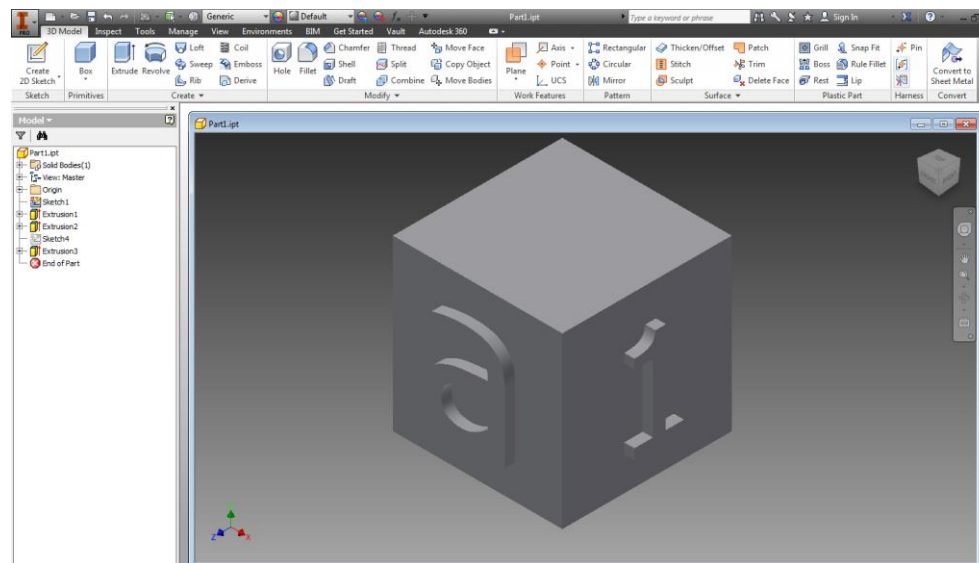

15. This is what it should look like when you are finished.

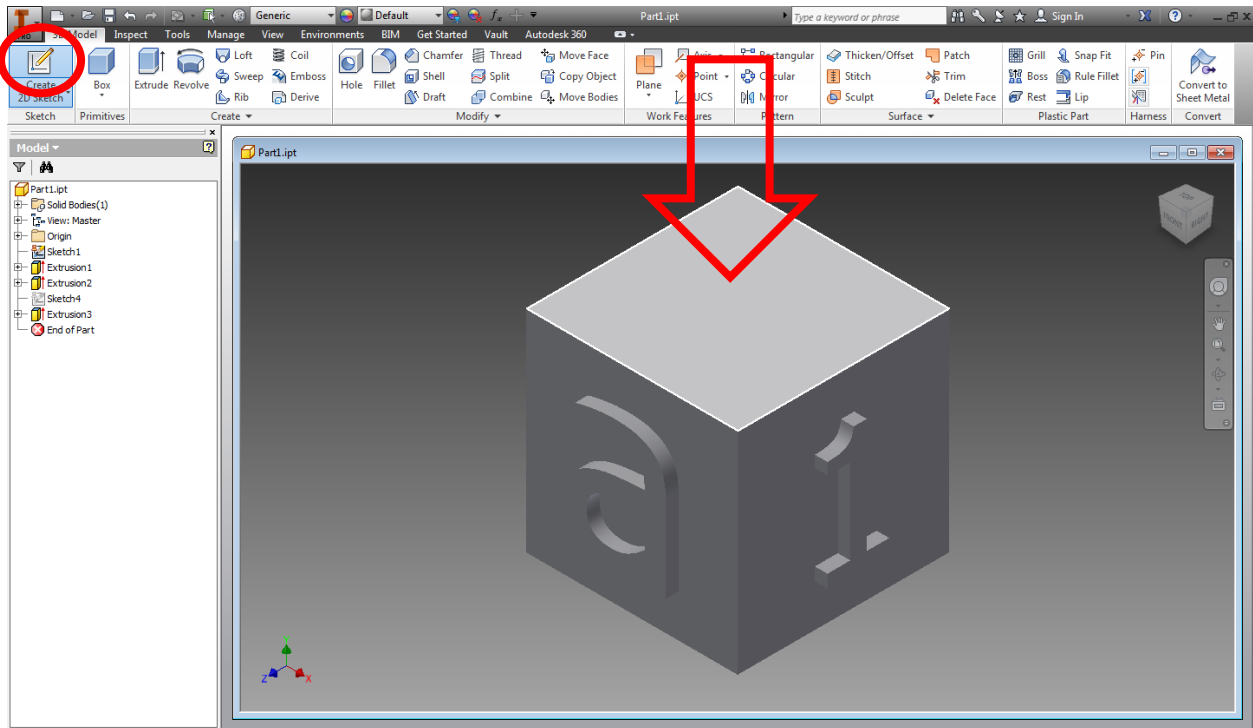

16. Now click on **CREATE 2D SKETCH** button then select top face of cube.

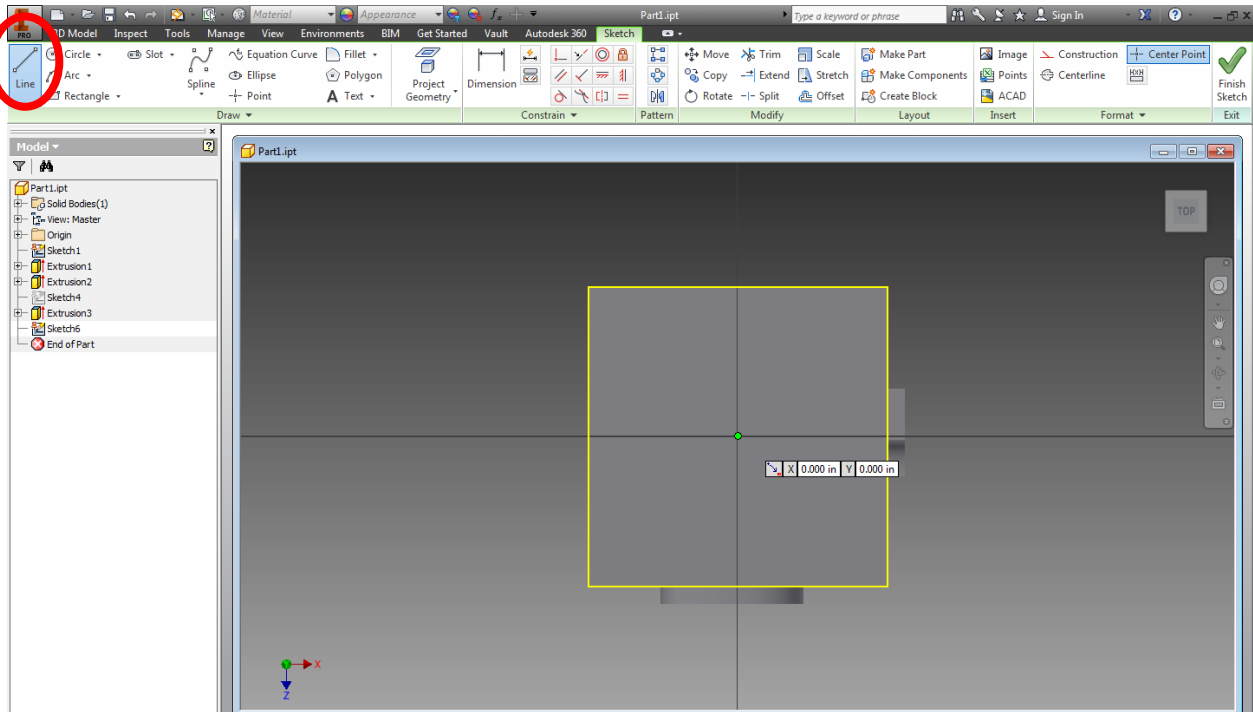

17. Now click on the **LINE** or other draw and modify buttons to draw the person's favorite shape.

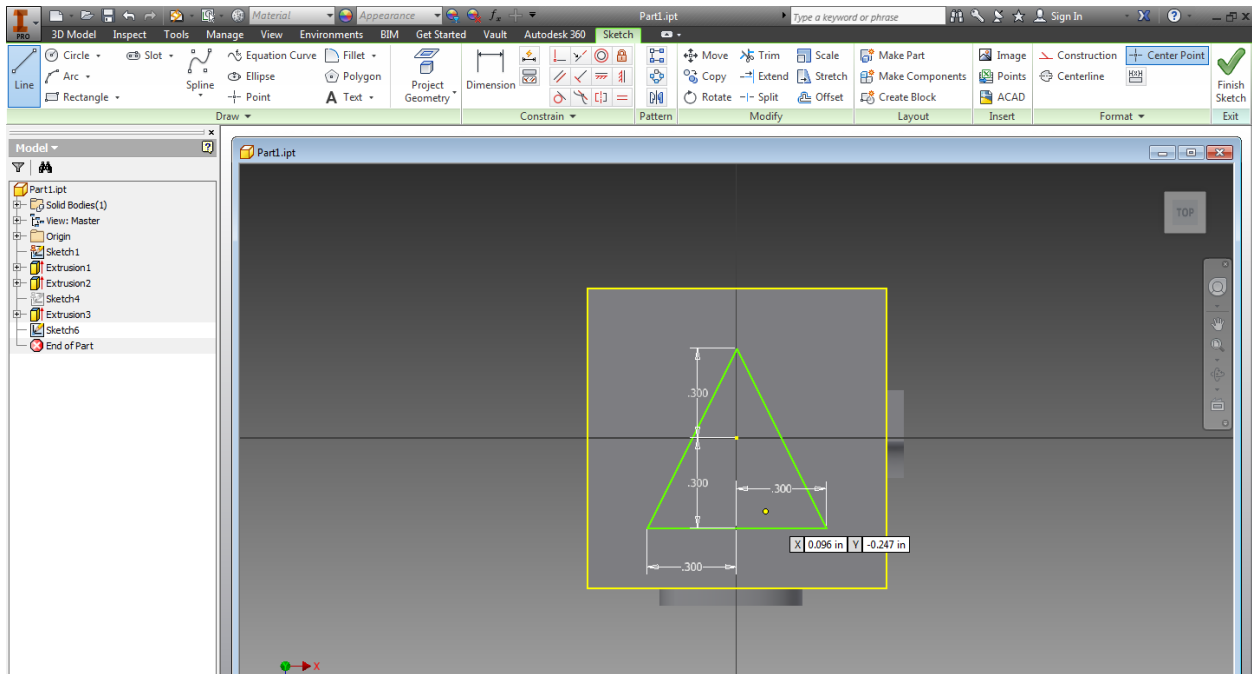

18. Here is an example of what it should look like. Make sure that the shape is centered on the cube.

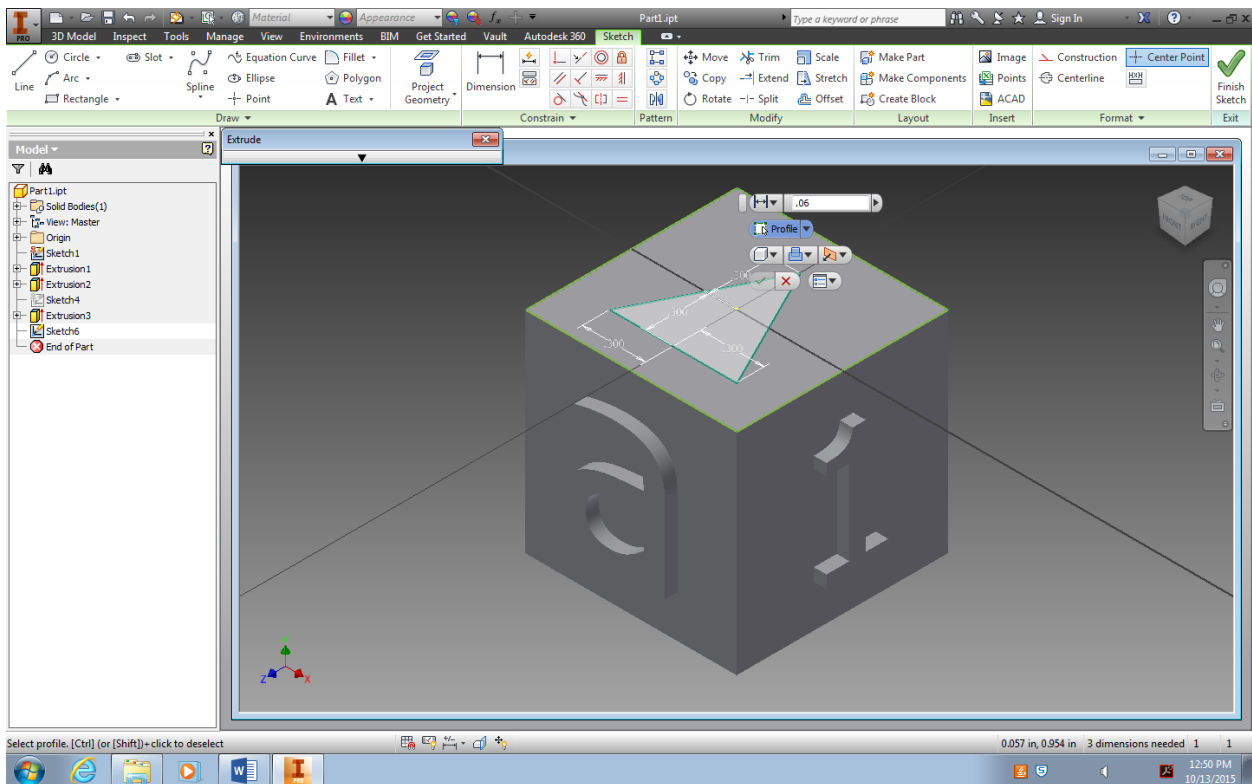

19. Now click **E** on your key board which is the hot key for **EXTURDE**, click on the shape to highlight it, then type in **.06**. When finished click green check mark.

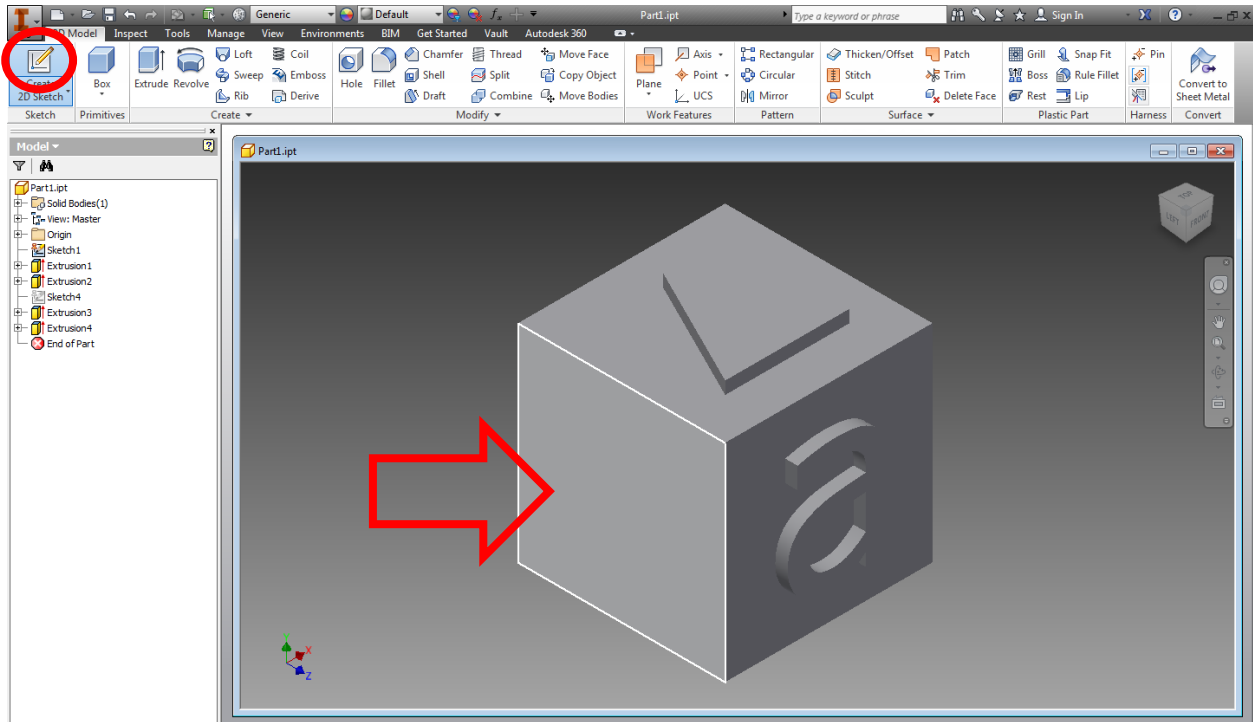

20. This is what your shape should look like after you extrude it . Now click on the **CREATE 2D SKETCH** button then select face next that is being pointed to in picture above and then repeat steps 5-11 but now you are going to put ROMEO or HAM-PAR, it is your choice. You will have to determine what size font to use in order for the word to fit on the face.

***NOTE:** When selecting a font, do not pick one that is of a thin style because the 3D printer will not be able to print it clearly.

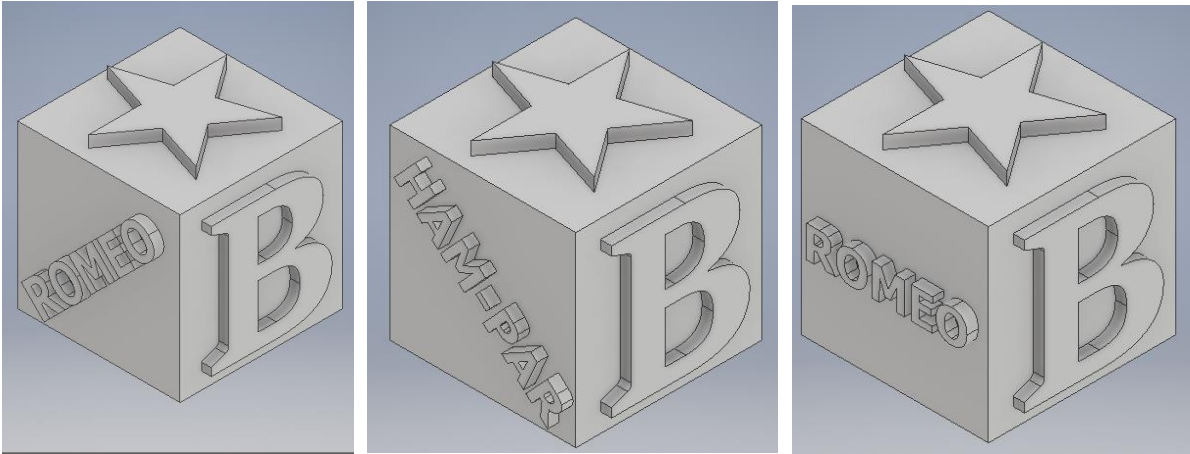

21. These are some options to what the face could look like.

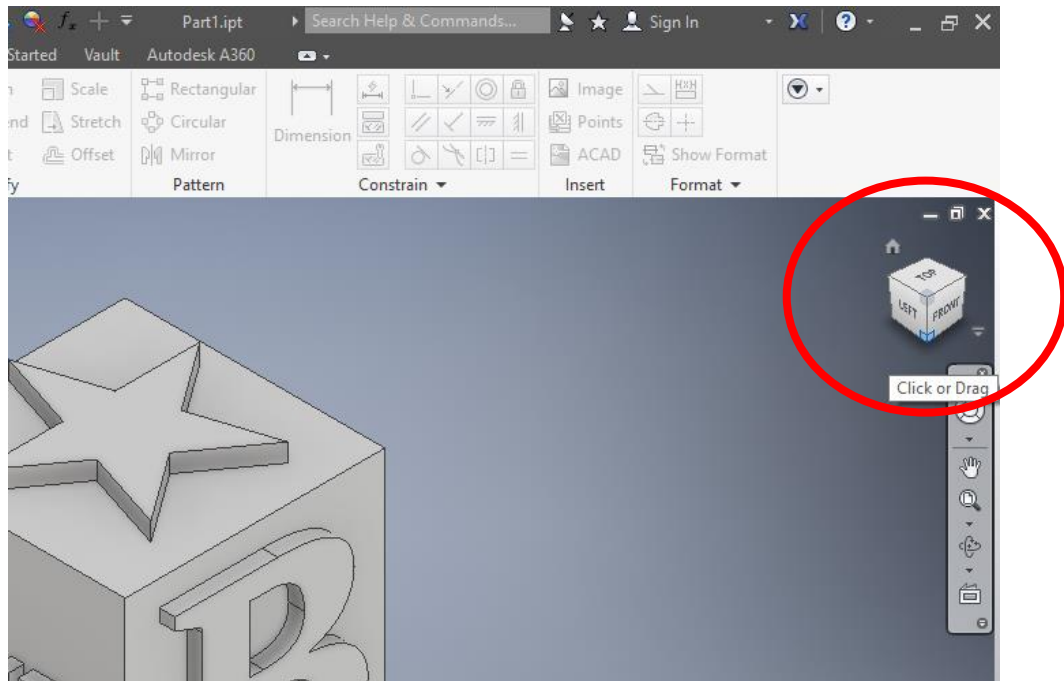

22. Click on the view cube so that the pencil topper rotates so you can select the bottom face.

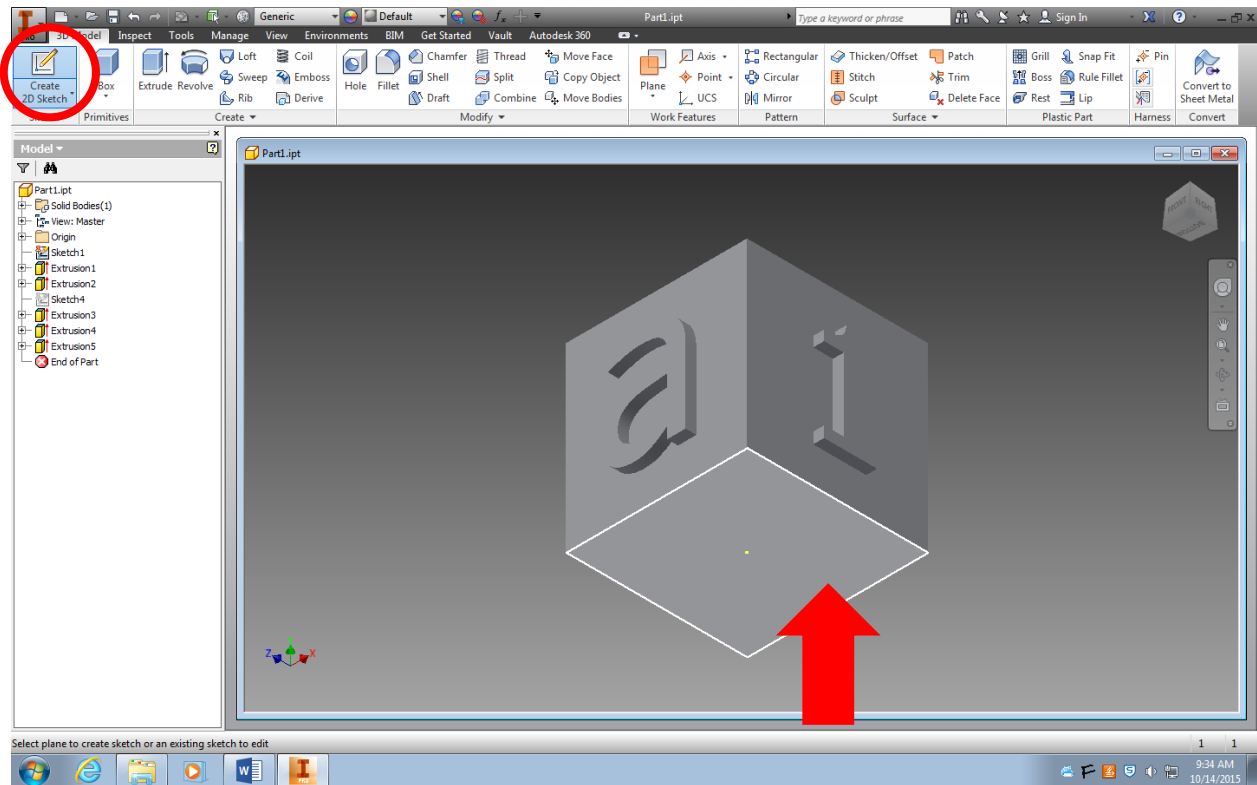

23. Click on **CREATE 2D SKETCH** then select the face of the cube that is being pointed to in the picture above.

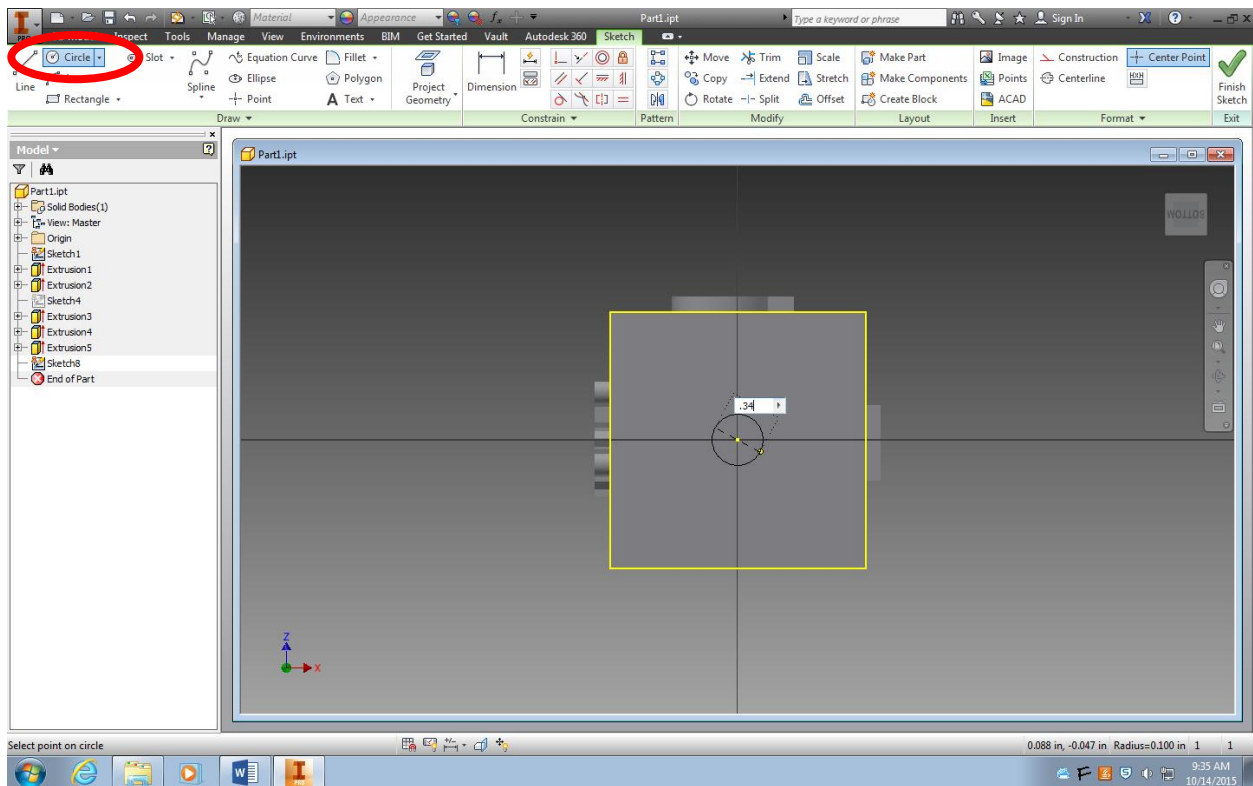

24. Click on the **CIRCLE** button, then click the center of your cube and type in **.33** for the pencil hole diameter then hit enter.

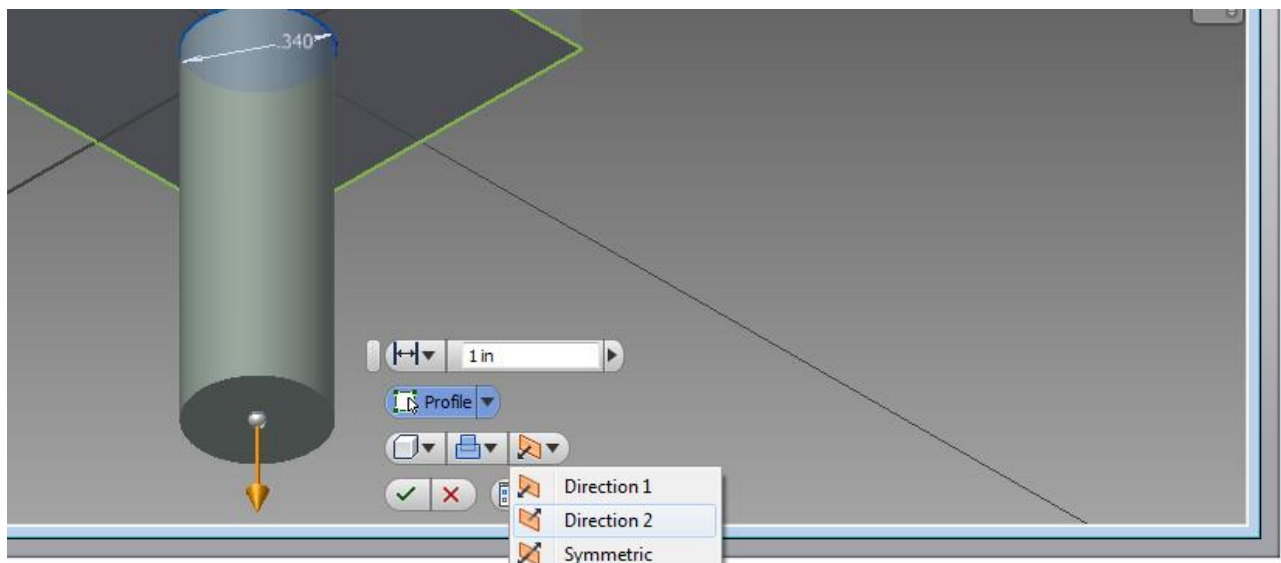

25. Now you are going to want to press E on your key board which is the hot key for extrude then click on the circle you drew, next your are going to click the button that is being pointed to in the picture then click on the **DIRECTION 2** button so it goes into the cube.

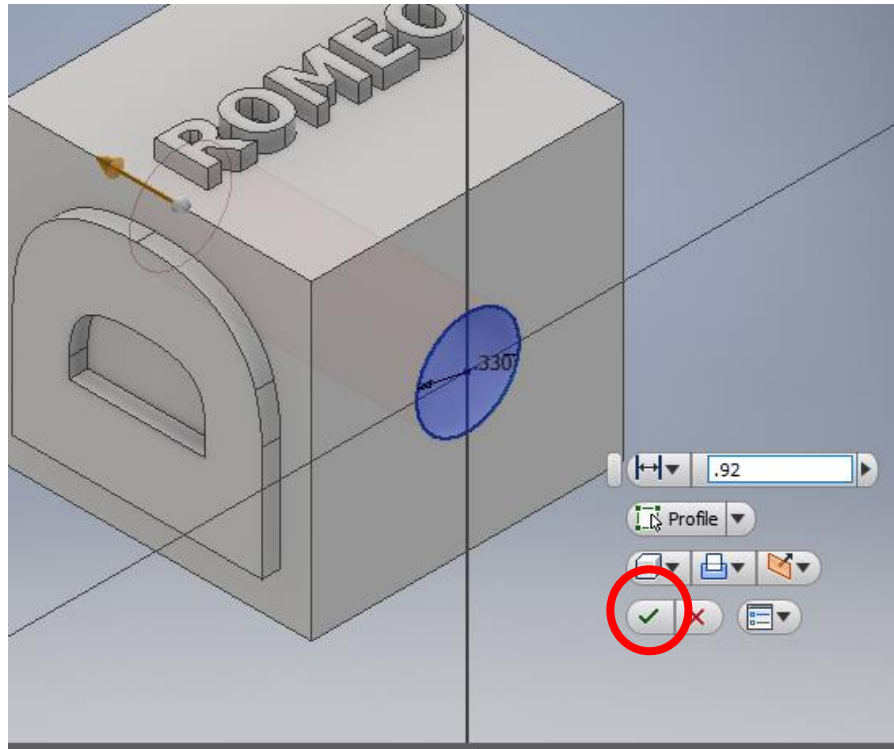

26. Now your circle should be going into the cube and type in **.92** then click the green check mark.

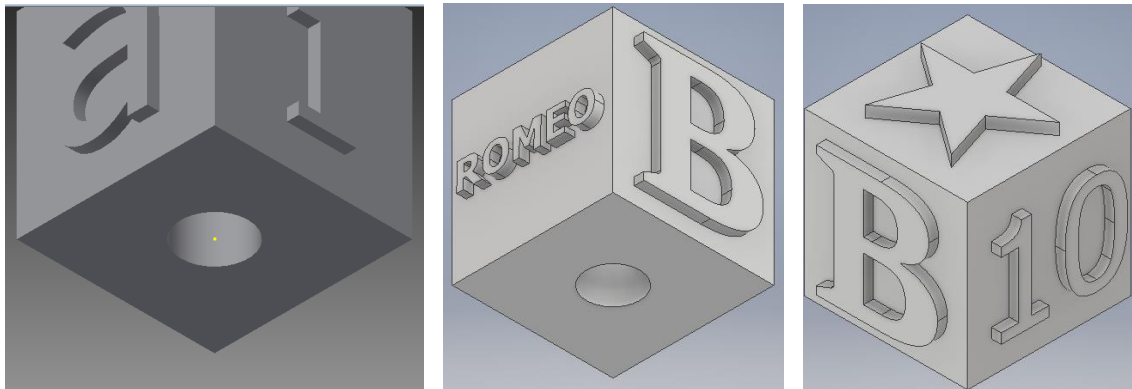

27. Use the ViewCube to rotate around the pencil topper to verify all sides are complete. Now you will be ready to 3D print! Be sure to **save** your file.

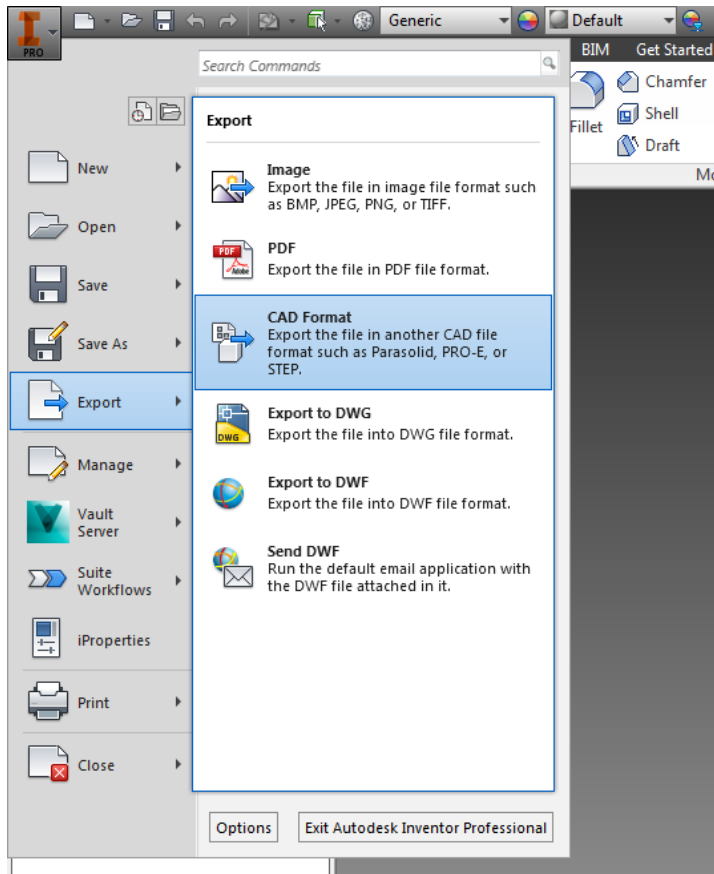

29. You will need to export your file to it can be printed to the 3D printer. Do this by going to File, Export, CAD Format, and save the file as an **.STL** format. Save your export into the the G: 00 PENCIL TOPPERS folder. It will also be named “ **HOUR-YOUR FIRST AND LAST NAME-PENCIL TOPPER-COLOR**”.stl so for example, **3-EVVA DOSSIN-PENCIL TOPPER-GREEN.stl**

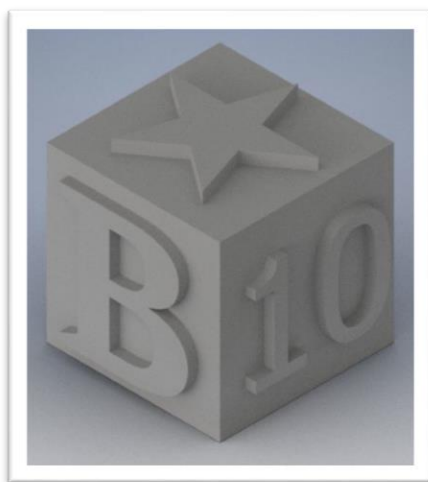

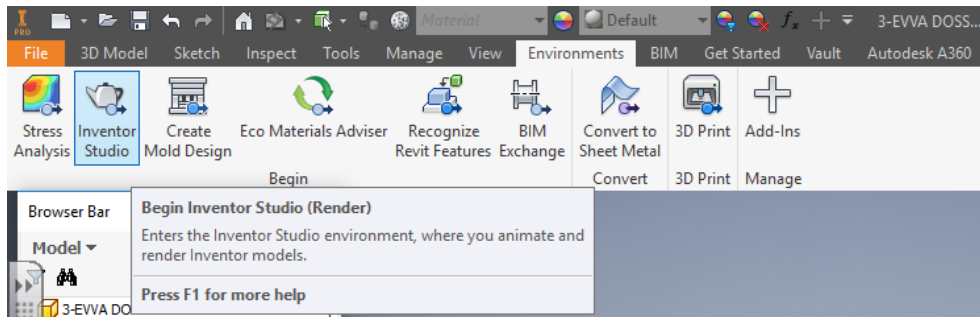

30. Render your 3D model in at least two perspective views to show all 6 sides and include them in your online portfolio. To render go to the **Environments** Tab and click on **Inventor Studio**. Click on **Render Image**, experiment with **Lighting Styles** as you wish and then click **Render**. When it is complete it will give you an option to save that image as a jpeg which can then be uploaded to your portfolio.

