

## Project: Sketched 4-Square

On an **A-size sheet** of plain paper do the following:

- a. Sketch a border approximately  $\frac{1}{4}$ " from the paper's edge.
- b. Draw a horizontal line approximately  $\frac{1}{2}$ " from the bottom border line for a title block area. Divide this title block into three sections for your **name**, **school**, and **date**. Fill in this information.
- c. Sketch horizontal and vertical lines to divide the drawing sheet into four rectangles. Label **1,2,3,4** at the **top-right hand** corner.
- d. In box 1, sketch the "Oil Seal Press", box 2 the "Holding Tool" and box 3 the "Washer" shown below. In box 4 sketch an object in the classroom such as the radio, a desk, bookcase etc.
- e. You do not need to show dimensions of the objects sketched but they need to be drawn to proportion.
- f. All sketches are to be **titled underneath** the sketch themselves.

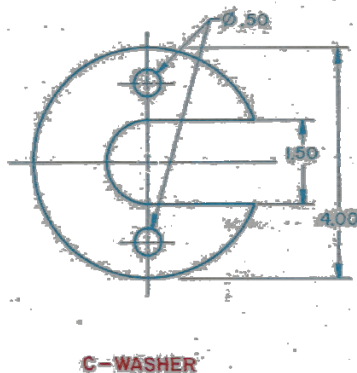
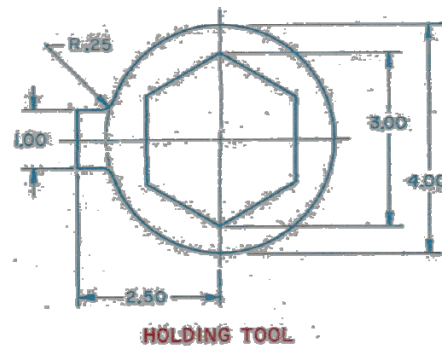
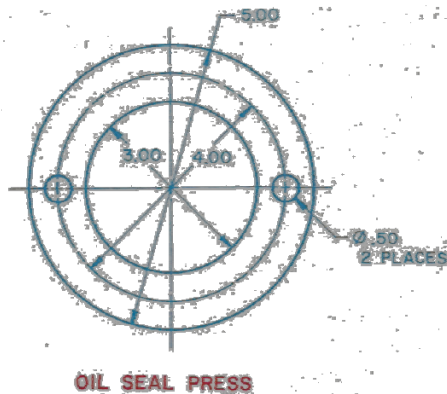

### ***What is the teacher looking for?***

1. Neatness in sketching and lettering and overall layout of drawing.
2. Ability to follow written and verbal directions. (Seg. 0)
3. Demonstrate sketching techniques (e.g. freehand lettering) (Seg. 2)
4. Demonstrate basic layout drawing (e.g. borders and information blocks) (Seg. 2)